

# Mathematical Modelling Living Systems Regulatory Mechanisms at the Norm and Anomalies

Mahruy Saidalieva, Mohiniso Baxromovna Hidirova \*

Scientific and Innovation Center of Information and Communication Technologies, Tashkent University of Information Technologies Named After Muhammad Al-Khwarizmi, Tashkent, Uzbekistan

## Email address:

mhidirova@yandex.ru (M. B. Hidirova)

\*Corresponding author

## To cite this article:

Mahruy Saidalieva, Mohiniso Baxromovna Hidirova. Mathematical Modelling Living Systems Regulatory Mechanisms at the Norm and Anomalies. *Software Engineering*. Vol. 5, No. 6, 2017, pp. 88-93. doi: 10.11648/j.se.20170506.12

**Received:** November 21, 2017; **Accepted:** December 1, 2017; **Published:** January 10, 2018

---

**Abstract:** The purpose of this paper is to develop methodology for living system regulatorika under norm and diseases based on the *ORASTA* concept which consists of the operator-regulator *OR* (capable to accept, recycle and transfer signals) and *ASTA* (active system with time average, carrying out a feedback loop in system for finite time). The paper draws on results made by using methods of quantitative and qualitative analysis of *ORASTA* equations. The paper concludes that living systems have the following regimes: rest, stable stationary state, regular oscillations which can be identified as normal condition and irregular fluctuations with destructive changes conform to diseases. The paper provides new methods, laws able to describe regulatory mechanisms in biosystem at the norm and anomalies taking into account spatial and temporal relations.

**Keywords:** Computer Modeling, Regulatory Mechanisms, Mathematical Modeling, Qualitative and Quantitative Analysis, Chaos, Nonlinear Dynamics

---

## 1. Introduction

Worldwide development of the theory and practice of the regulatory mechanisms functioning of living systems at the main hierarchical levels of the organization is connected with its successful application to biology, medicine and agriculture, because it allows to choose the most effective ways for diseases prophylaxis and treatment, for agricultural techniques of cultivation and plant selection, to creation various biotechnology products. The works, devoted to different types of mathematical modeling of living system regulatory mechanisms, by B. Goodwin, J. Smith, M. Eigen, V. A. Ratner, E. E. Selkova, D. S. Chernavsky (subcellular level); Antomonov, Sendov, R. Tsanev (cellular level); L. I. Lischetovich, Y. Kibardin, K. K. Dzhanseitov (organ-tissue level); N. Rashevsky, A. M. Molchanov, G. I. Marchuk (organismal level) and other are discovered basics mechanisms of biosystem regulation at considered levels, permitting using mathematical modeling to solve medical and biological problems.

However, to date, there is no united approach to create

mathematical models and effective methods for the quantitative analyzing regulatory mechanisms of living systems, taking into account spatial and temporal organization.

## 2. Materials and Methods

The concept of the regulatorika and *ORASTA*

Regulatorika is the science that involves the study of interconnected activity of regulatory mechanisms based on the *ORASTA* concept which consists of the operator-regulator *OR* (capable to accept, recycle and transfer signals) and *ASTA* (active system with time average, carrying out a feedback loop in system for finite time). Using *ORASTA* the functional-differential equations taking into account stimulating and inhibiting interactions, temporal relations, combined feedback and cooperativity in considered processes are developed [1]:

$$\frac{dX_i(t)}{dt} = A_i^N(X(t-h)) \exp\left(-\sum_{k=1}^N \delta_{ik} x_k(t-h_{ik})\right) - b_i X_i(t) \quad (1)$$

where

$$A_i^N(X(t-h)) = a_{i0} + \sum_{j=1}^N \left( \sum_{k_1, \dots, k_j=1}^N a_{ik_1, \dots, k_j} \prod_{m=1}^j x_{k_m}(t-h_{ik_m}) \right)$$

and with initial conditions

$$X_i(t) = \varphi_i(t) \text{ at } t_0 - h \leq t \leq t_0 \\ (t_0 > h), i, j, k_j = 1, 2, \dots, N.$$

Here  $x_i(t)$  are the sizes characterizing quantity of a signals, developed by  $i$ -th OR at the time moment  $t$ ;  $h_{ik}$  are a time intervals necessary for  $i$ -th OR activity changing under the  $k$ -th OR activity influence;  $a_{i0}$ ,  $b_i$  are parameters of formation and disintegration speeds of  $i$ -th signal, accordingly;  $\varphi_i(t)$  are continuous, positive initial functions. It is entered the vector  $\mu_c(C_1, \dots, C_n)$ , describing mutual relations between biological systems and external medium. Here

$$C_i = \int_0^\infty \dots \int_0^\infty A_i^N(S) \exp\left(-\sum_{j=1}^N \delta_{ij} S_j\right) dS_1 \dots dS_N - b_i.$$

Let us consider regulatorika equations in the following common form

$$\frac{dx_i(t)}{dt} = F(x_1(t-h_1), x_2(t-h_2), \dots, x_n(t-h_n)) - b_i x_i(t).$$

The regulatorika equations can be considered in the following form

$$\frac{1}{h_i b_i} \frac{dx_i(t)}{dt} = F(x_1(t-1), x_2(t-1), \dots, x_n(t-1)) - x_i(t).$$

The vector of mutual relations between biosystem and an environment is

$$\mu_c = \int_0^\infty F(s) ds - b$$

and

$$h = (h_1, h_2, \dots, h_n), b = (b_1, b_2, \dots, b_n),$$

$$\frac{k_1}{b} = \rho, k_2 h = r.$$

The following regulatorika laws are formulated. The law of regulatorika energy conservation:

$$\mu_c = 0.$$

The adjustability law: The system is called regulated, if internal temporal conditions inversely proportional to external,

$$hb = 1, h, b$$

are the vectors.

The law of a normal regulatorika: There exist such systems

of regulatorika named normal, in which internal temporal conditions are in the balance with the external (see Figure 1).

$$\rho = r, \mu_c = 1.$$

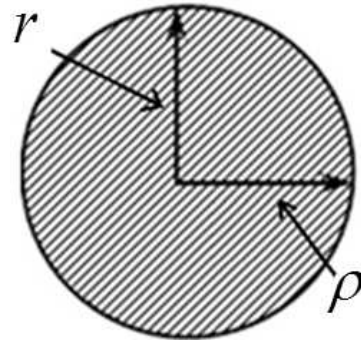

Figure 1. Normal regulatorika, in which internal temporal conditions are in the balance with the external.

The law of a supernormal regulatorika: There exist such systems of regulatorika named supernormal, in which internal temporal conditions more than the external (Figure 2).

$$m_c > 1, \rho > r, hb < 1.$$

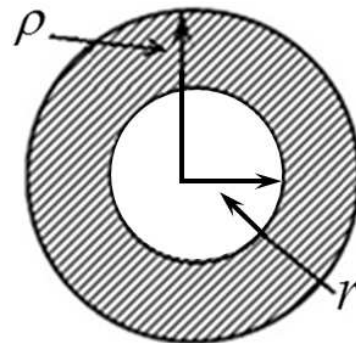

Figure 2. Supernormal regulatorika, in which internal temporal conditions more than the external.

The law of an insufficient regulatorika: There exist such systems of regulatorika named insufficient, in which internal temporal conditions less than the external (Figure 3):

$$m_c < 1, \rho < r, hb > 1.$$

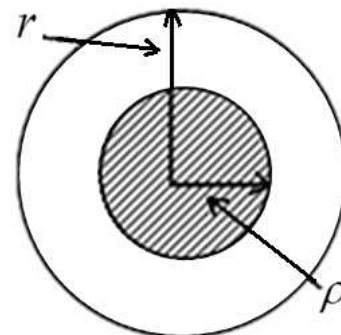

Figure 3. Insufficient regulatorika, in which internal temporal conditions less than the external.

Next section is devoted to applying regulatorika concept for analyzing the interconnected activity between molecular-genetic systems of hepatocytes and hepatitis B viruses taking into account microRNA action.

### 3. Results

Realization of the concept

Infection with the hepatitis B virus (HBV) remains a global health problem and it is estimated that about 2 billion people worldwide are infected with this virus, more than 350 million people are sick. Chronic HBV infection can lead to primary carcinoma of the liver. The genome of the hepatitis B virus encodes microRNA. These viral microRNAs can participate in suppressing the expression of own viral genes. The regulatory mechanisms of microRNA action have not been studied in detail. Disclosure of the regulatory mechanisms of the microRNA action will help to determine the mechanisms of formation and development of the infectious process at viral hepatitis B at the molecular genetic level and will allow finding effective ways for targeted therapeutic and preventive influence on the molecular-genetic system of the liver cells. Taking into consideration that the hepatitis B virus by its microRNA affects the cell, suppressing it (Figure 4), then equations of minimal mathematical model for interconnected regulatorika between hepatocyte and viral microRNA molecular-genetic systems have the following kind

$$\begin{aligned} \frac{\theta_1}{h} \frac{dX_1(t)}{dt} &= a_1 X_1(t-1) e^{-X_1(t-1)-X_2(t-1)} - X_1(t); \\ \frac{\theta_2}{h} \frac{dX_2(t)}{dt} &= a_2 X_1(t-1) X_2(t-1) e^{-X_1(t-1)-X_2(t-1)} - X_2(t), \end{aligned} \quad (2)$$

where  $X_1(t)$  is the concentration of hepatocyte mRNA;  $X_2(t)$  is the concentration of the hepatitis B virus microRNA;  $\theta_1, \theta_2$  are corresponding average activity durations of hepatocyte and hepatitis B virus molecular-genetic systems, respectively;  $h$  is the time radius of the cell (the time required for carrying out the feedback of molecular genetic systems);  $a_1, a_2$  are non-negative constants, expressing the resource availability for considered genes systems and products.

The system equation (2) has a trivial equilibrium position, has instability of infinitely distant points in the first quadrant of phase space and a nonnegative solution for nonnegative initial values of the functions. The coordinates of the equilibrium position  $\xi(\xi_1, \xi_2)$  are determined from equations

$$\begin{aligned} a_1 \xi_1 e^{-\xi_1 - \xi_2} - \xi_1 &= 0; \\ a_2 \xi_1 \xi_2 e^{-\xi_1 - \xi_2} - \xi_2 &= 0. \end{aligned} \quad (3)$$

Researching equation (3) solutions we find that when

$$a_1 > 1, \quad a_2 > e$$

there are non-trivial equilibrium positions for equation (2).

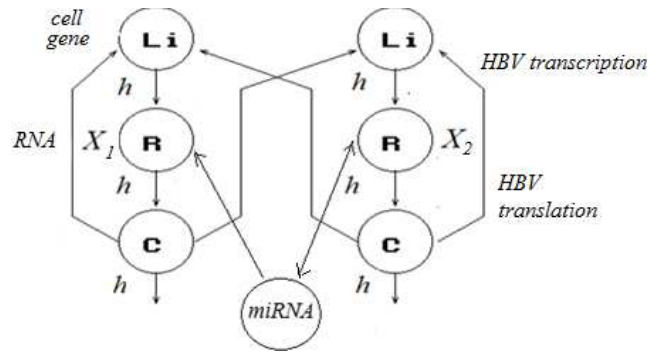

Figure 4. Interconnected regulatorika between hepatocyte and viral microRNA molecular-genetic systems.

Here in Figure 5, in F area there is only a trivial equilibrium position, in G and H areas there is a nontrivial equilibrium position, and in G area the equilibrium position of the dependent equation in equation (2) is trivial.

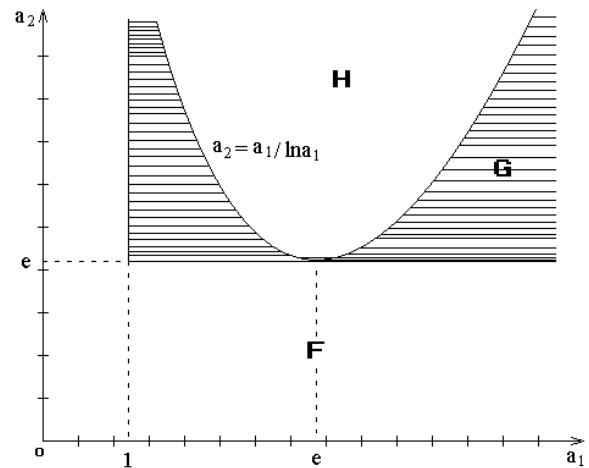

Figure 5. Parametric portrait for equation (2).

Let us analyze the stability nature of equilibrium positions for equation (2).

Introducing small  $z_1(t), z_2(t)$  near  $\xi(\xi_1, \xi_2)$  we have

$$X_1(t) = \xi_1 + z_1(t), \quad X_2(t) = \xi_2 + z_2(t).$$

After linearization we have

$$\begin{aligned} \frac{\theta_1}{h} \frac{dz_1(t)}{dt} &= \alpha(1 - \xi_1) z_1(t-1) - \alpha \xi_1 z_2(t-1) - z_1(t); \\ \frac{\theta_2}{h} \frac{dz_2(t)}{dt} &= \beta \xi_2 (1 - \xi_1) z_1(t-1) - \beta \xi_1 (1 - \xi_2) z_2(t-1) - z_2(t), \end{aligned}$$

where

$$\begin{aligned} \alpha &= a_1 e^{-\xi_1 - \xi_2}; \\ \beta &= a_2 e^{-\xi_1 - \xi_2}. \end{aligned}$$

In the case of a trivial equilibrium position, we have

$\alpha = a_1 e$ ;  $\beta = a_2$  and

$$\begin{aligned} \frac{\theta_1}{h} \frac{dz_1(t)}{dt} &= a_1 z_1(t-1) - z_1(t); \\ \frac{\theta_2}{h} \frac{dz_2(t)}{dt} &= -z_2(t). \end{aligned} \quad (4)$$

Analysis equation (4) shows that there is stability for trivial equilibrium position  $0(00)$  at  $a_1 < 1$ . Near non-trivial equilibrium positions we have the following characteristic equation

$$\left( \frac{\theta_1}{h} \lambda - 1 + (1 - \xi_1) e^{-\lambda} \right) - \left( \frac{\theta_2}{h} \lambda - 1 - e^{-\lambda} \right) = 0. \quad (5)$$

Analysis equation (5) shows that there is the stability by  $X_1$  and there is the instability possibility for given equilibrium position by  $X_2$  at

$$\ln a_1 > 1 + \frac{\theta_1}{h} \eta \sin \eta - \cos \eta,$$

where  $\eta$  is the root of the following equation

$$\eta = -\frac{h}{\theta_1} \operatorname{tg} \eta, \quad 0 < \eta < \pi.$$

The presence of a trivial attractor means that for the elements activation of the regulatory system, it is required a certain threshold influence that removes the system from the basin of the trivial attractor. The existence of non-trivial equilibrium positions means that considered system has a potential functional activity with an infinite attractor basin. In addition for regulatorika equations we can use approximated functional-differential equations and its discrete analogy when we consider the concrete biological systems [2], [3], [14]. It is necessary to note that discrete recurrent equations as model systems for equation (2) are especially useful, because, in this case we can apply such methods as Lamerey diagrams construction [3], calculation of Lyapunov number [4], definition of "chaotic degree" [5]. Computer investigations with model equations for equation (1) and equation (2) have shown that the non-trivial attractor can lose own stability depending on various time delay and external influence according regulatorika laws and can have such solutions behavior that can be identified as normal functioning (stationary regime and regular oscillation mode or Poincare type limit cycles (Figure 6) and as anomalous behavior (irregular oscillations (Figure 7) and the "black hole" effect (Figure 8). This allows to model the normal and anomalous states of real biological systems [6] and to solve correction problems to improve their functioning [7], [8].

Researches show that in chaos area there are small regions with normal behavior called "r-windows". Quantitative researches have shown that the basic characteristics of "r-windows" (quantity, the sizes and location) have nonlinear, difficult character. For example, if parameters of resource availability and a associativity are increasing then it does not

necessarily mean that number of "r-windows" must to increase. The organism, using adaptive mechanisms, can enter into the nearest region of regular decisions. It means normal activity of biosystem.

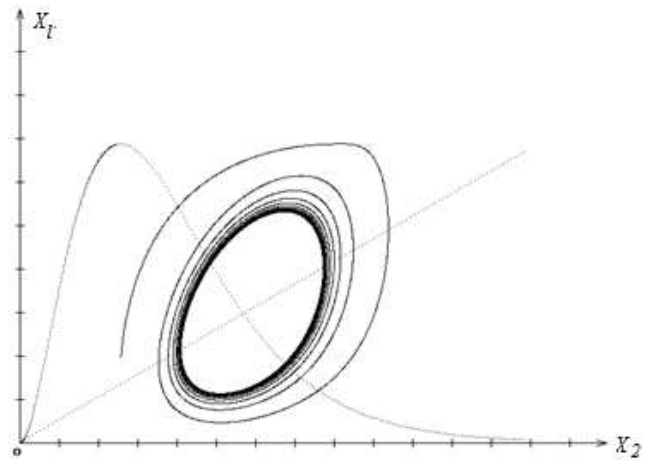

Figure 6. Poincare type limit cycles in model system for equation (2).

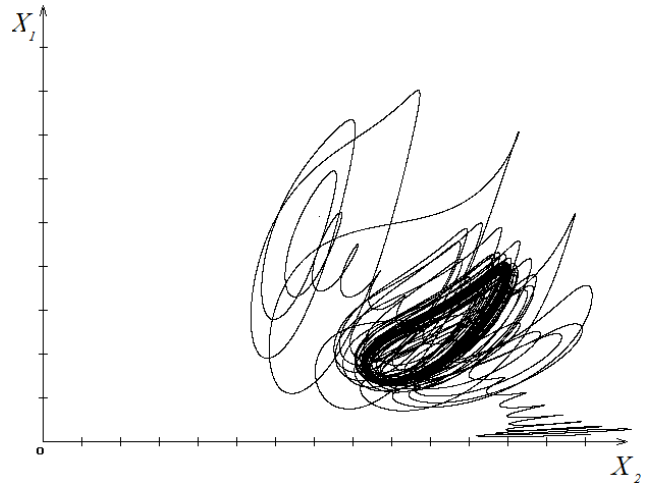

Figure 7. Chaos in the model system for equation (2).

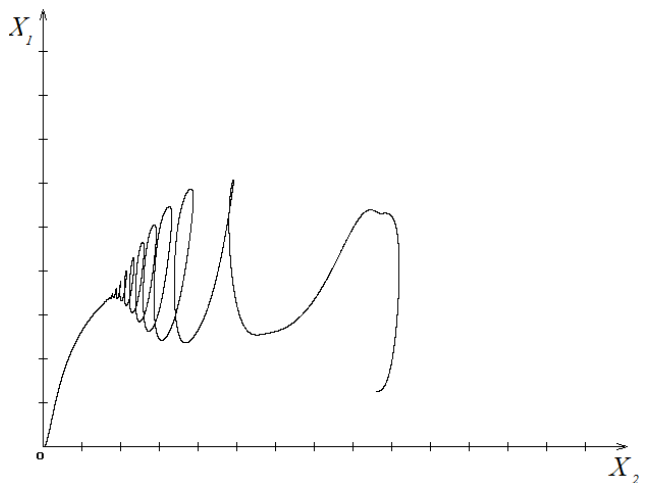
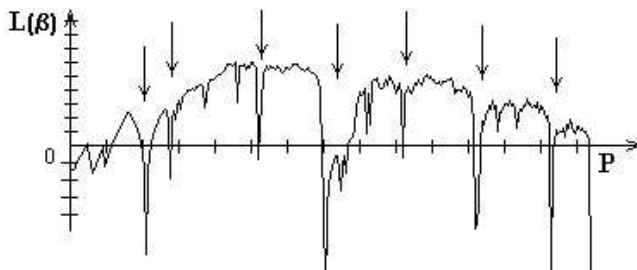

Figure 8. "Black hole" in the model system for equation (2).

Dynamics of Lyapunov number, calculated on PC for

discrete analogy for model system (2), help to estimate "chaotic degree" and to investigate the small regions with normal regulatorika ("r-windows") in chaos area at various parameters values (Figure 9).

A common analysis of equation (1) and equation (2) and a series of computational experiments make it possible to determine that the hepatitis B virus's molecular-genetic system have an influence on the hepatocyte based on the *inhibition mechanism*. The functioning suppression of the hepatocyte molecular-genetic system is directly proportional to the activity level the virus's molecular genetic system (in particular, to the level of microRNA concentration). Moreover, suppression has an exponential nature. This means that the suppression intensification occurs not in a linear and not in a multiple, but exponential degree. Evidently, this mechanism determines the often observed transcendence of virus's molecular-genetic systems in mutual functioning.



**Figure 9.** Dynamics of Lyapunov number in the model system for equation (2) (arrows show "r-windows").

The next mechanism of interaction between hepatocytes and hepatitis B viruses we can reveal by analyzing solutions behavior in dependence on the parameters changing. The solutions transition from the normal behavior into the area of unpredictable behavior and sharp destructive changes occurs with the increased growth of the resource parameter value. Consequently, the mechanism for the interaction between hepatocytes and hepatitis B viruses is the intensification mechanism of genes productivity in hepatocyte, which is imposed by hepatitis B viruses.

The analysis results show that there is the mechanism of temporary improvement of the hepatocyte state in the field of unpredictable behavior. A hepatocyte, which is in area of unpredictable behavior, may enter inside a small region with "r-windows" and relatively improve its state, since the systems behavior inside the "r-windows" is regular. Researches results and defined regulatory mechanisms allows, at computer support of laboratory and clinical researches of infectious process at hepatitis B, to define molecular-genetic bases of pathogenesis at different level of microRNA concentration, to carry out diagnostics and forecasting of characteristic stages of disease course during hepatitis B.

Thus existence of the following regimes of regulatorika between molecular-genetic system of hepatitis B viruses and hepatocytes has been revealed: monotonous reduction, stationary condition, self-oscillations, irregular fluctuations (chaos), sharp destructive chaos death ("black hole" effect).

Researches results show existence of the following regulatory mechanisms during diseases development: the inhibition mechanism, the mechanism of mobilization of potential possibilities of an organism at anomalies, the mechanism of temporal improvement of system.

## 4. Conclusions

The methods, laws and mechanisms of living systems regulatorika make it possible to effectively analyze the biological systems regulatory mechanisms functioning at the norm and anomalies. Methods for qualitative and quantitative analysis of "black hole" effect appearance regularities allow to evaluate the conditions for destructive changes beginning, which is very important for practical medicine. For a qualitative study of living systems functioning mechanisms, we can use the system of differential-delay equations and its model systems in the form of functional and discrete equations. Among the model systems for differential-delay equations, the discrete model systems are the most simple and convenient for qualitative and quantitative studies of living systems regulatorika. Computer analysis with the construction of Lamerey diagrams, Lyapunov number calculation make it possible to quickly evaluate the general pattern, characteristic features and basic behavior regimes for solutions of equations (1). Methods of qualitative and quantitative analysis of living systems regulatorika equations make it possible to obtain approximate solutions of nonlinear differential-delay equations, to evaluate the behavior of irregular solutions and "chaos degree", to analyze the functioning patterns of living systems. It is especially important to study the structural features of the dynamic chaos region, to identify areas with regular behavior ("r-windows") in the environment of irregular oscillations, since the presence of small regions with normal behavior in the region of anomalies makes it possible to choose a possible path for withdrawing the system state from the region of irregular functioning to the region with the normal state. The obtained results can be used to develop information technology tools for quantitative studies of living systems at the basic levels of biosystems organization at the norm and at various diseases.

## References

- [1] Hidirov, B. N. (2014). Selected works on mathematical modeling for regulation of living systems. Moscow: ICI. 304. (In Russ.).
- [2] Saidalieva M. (2003). Modelling of Regulation Mechanisms of Cellular Communities // *Scientiae Mathematicae Japonicae*. Published bimonthly by International Society for Mathematical Sciences. Kyoto University – Japan. 58 (2): 415-421.
- [3] Abduvaliev A., Saydalieva M., Hidirova M., Gildieva M. (2015). Mathematical Modeling of the Thyroid Regulatory Mechanisms // *American Journal of Medicine and Medical Sciences*. USA. 3 (3): 28-32.

- [4] Saidalieva M. (2006). Simulation of cellular communities mechanisms // *Scientiae Mathematicae Japonicae*. Published bimonthly by International Society for Mathematical Sciences. Kyoto University - Japan. 64 (2): 469-478.
- [5] Saatov T. S., Hidirov B. N., Saidalieva M., Hidirova M. B. (2006). Mathematical Modeling of Apoptosis Regulatory Mechanisms // *World Scientific Books*. 1-17.
- [6] Aliev B. R., Hidirov B. N., Saidalieva M., Hidirova M. (2007). Quantitative Study of Cellular Mechanisms of HIV Infection's Pathogenesis // *Engineering Letters*. 13 (3): 304-307.
- [7] Aliev B. R., Hidirov B. N., Saidalieva M., Hidirova M. B. (2007). Mathematical and computer modeling of molecular-genetic mechanisms of liver cells infection by hepatitis B virus // *World Scientific Books*. 89-103.
- [8] Saidalieva M., Hidirova M. B. (2014). Functional-differential equations of biological communities regulatorika. // *ISJ Theoretical & Applied Science*. 4 (12): 7-11.
- [9] Saidalieva M. (2008). Mathematical and Computer Modelling Regulatorika of Organisms Cellular Communities at Anomalies // *Scientiae Mathematicae Japonicae*. Japan. Published bimonthly by International Society for Mathematical Sciences, Kyoto University. 67 (2): 161-171.
- [10] Hidirova M. B., Saidalieva M. (2017). Regulatorika of the immune system at the cellular level at the norm and tumor process. *ISJ Theoretical & Applied Science*. 09 (53): 113-118.
- [11] Hidirova M. B., Shakarov A. R. (2017). Mathematical modeling regulatory mechanisms of immune reactions at skin anomalies. *ISJ Theoretical & Applied Science*. 09 (53): 119-124.
- [12] Hidirova M., Yusupova Z. (2017). Mathematical Model of the Regulatory Mechanisms of Heart for Quantitative Analyzing of Big Data // *The 4th international conference on big data applications and services (BIGDAS2017)*. 257-263.
- [13] Abduvaliev A. A., Gildieva M. S., Saidalieva M. Hidirova M. B. (2017). Possibilities of mathematical modeling of the regulatorycs of the immune system in carcinogenesis // *Abstracts of the Uzbek-Israel international scientific conference "Contemporary problems in mathematics and physics"*. 13-14.
- [14] Saidalieva M. Hidirova M. B. (2017). Regulatorika of biological excitable media // *Abstracts of the Uzbek-Israel international scientific conference "Contemporary problems in mathematics and physics"*. 104-105.